

STRENGTH & FITNESS
RUGGED

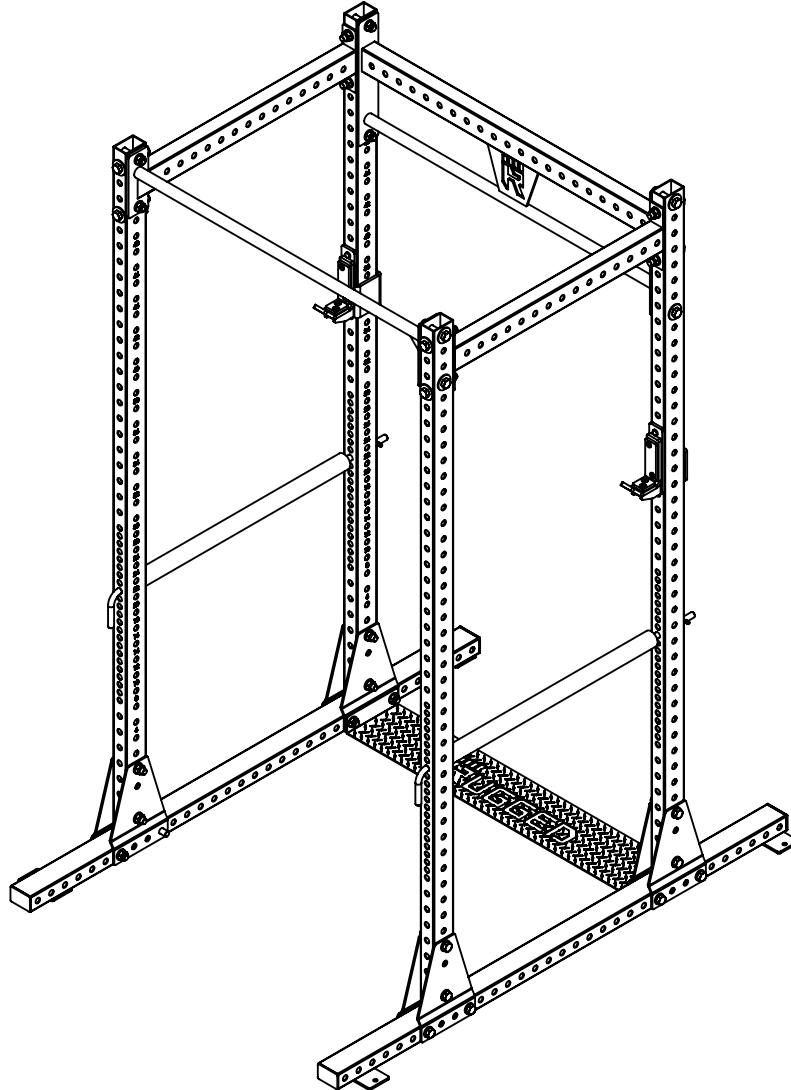

**WARRIOR
POWER RACK**

SKU# Y100

Assembly & Instructions
OWNER'S & MANUAL

Y100-020818

Warning, Safety & Maintenance

Be sure that all users carefully read and understand all warning, safety and maintenance labels on the machine before each use. Failure to do so may result in death or serious injury.

It is imperative that you retain this Owner's Manual and be sure all warning labels are legible and intact. Replacement Owner's Manuals and warning labels are available from Rugged Fitness.

If you have any questions about the operation, set up or maintenance of this machine please call our customer service department at 1 (800) 556-3113.

Table of Contents

- SAFETY INSTRUCTIONS..... PAGE 4
- PREPARATION..... PAGE 5
- HARDWARE ILLUSTRATION..... PAGE 6
- PARTS / HARDWARE LIST..... PAGE 8
- PARTS ILLUSTRATION..... PAGE 9
- ASSEMBLY INSTRUCTIONS..... PAGE 12
- EXPLODED VIEW..... PAGE 21
- CONTACT PAGE..... PAGE 22

Important Safety Instructions

Before beginning any fitness program, you should obtain a complete physical examination from your physician.

*Il est conseillé de subir un examen médical complet avant d'entreprendre tout programme d'exercice.
Si vous avez des étourdissements ou des faiblesses, arrêtez les exercices immédiatement.*

Antes de comenzar cualquier programa de ejercicios, deberías tener un examen físico con su doctor.

When using exercise equipment, you should always take basic precautions, including the following:

- Read all instructions before using this equipment. These instructions are written to ensure your safety and to protect the unit.
- **Do not remove any safety labels from the machine.**
- Do not allow children on or near the equipment.
- Use the equipment only for its intended purpose as described in this guide. Do not use accessory attachments that are not recommended by the manufacturer. Such attachments might cause injuries.
- Wear proper exercise clothing and shoes for your workout, no loose clothing.
- Keep hands, limbs, loose clothing, and long hair well out of the way of all moving parts.
- Use care when getting on or off the unit.
- Do not overexert yourself or work to exhaustion.
- If you feel any pain or abnormal symptoms, stop your workout immediately and consult your physician.
- Never operate unit when it has been dropped or damaged. Return the equipment to a service center for examination and repair.
- Never drop or insert objects into any opening in the equipment.
- If the machine is equipped with cables, always check its cables before each use. Make sure that all fasteners and cables are secure and in good working condition.
- Do not use the equipment outdoors or near water.

Personal Safety During Assembly

- Before beginning assembly, please take the time to read the instructions thoroughly.
- Read each step in the assembly instructions and follow the steps in sequence. Do not skip ahead. If you skip ahead, you may learn later that you have to disassemble components and that you may have damaged the equipment.
- Assemble and operate the equipment on a solid, level surface. Locate the unit a few feet from the walls or furniture to provide easy access.

This equipment is designed for your enjoyment. By following these precautions and using common sense, you will have many safe and pleasurable hours of healthful exercise with your **RUGGED FITNESS POWER RACK**.

After assembly, you should check all functions to ensure correct operation. If you experience problems, first recheck the assembly instructions to locate any possible errors made during assembly. If you are unable to correct the problem, call **1-800-556-3113** for customer assistance.

Obtaining Service

Please use this Owner's Manual to make sure that all parts have been included in your shipment. When ordering parts, you must use the part number and description from this Owner's Manual. Use only RUGGED FITNESS replacement parts when servicing this machine. Failure to do so will void your warranty and could result in personal injury.

For information about product operation or service, check out the official RUGGED FITNESS website at www.ruggedfitness.com or contact RUGGED FITNESS customer service at one of the following:

Toll Free: 1-800-556-3113
Phone: 1-708-427-3555
Fax: 1-708-427-3556
Hours: M-F 8:30-5:00 CST
E-Mail: service@ruggedfitness.com

**Or write to: Rugged Fitness
Service Department
1900 S. Des Plaines Ave.
Forest Park, IL 60130 USA**

Retain this Owner's Manual for future reference. If you need to order replacement parts please be prepared to provide the following information when contacting us so that we can assist you better.

- 1. Model Number**
- 2. Place of Purchase**
- 3. Serial Number (S/N)**
- 4. Part # and Description**

Preparation

Required Tools

The basic tools that you must obtain before assembling the **Y100** include but are not limited to:

- Standard Wrench Set
- Metric Wrench Set
- Adjustable Wrench

Installation Requirements

Follow these installation requirements when assembling the **Y100**. Set up the **Y100** on a solid, flat surface. A smooth, flat surface under the machine helps keep it level. A level machine has fewer malfunctions.

Provide ample space around the machine. Open space around the machine allows for easier access.

For aesthetic purposes, insert all bolts in the same direction unless specified (in text or illustrations) to do otherwise.

Leave room for adjustments. Tighten fasteners such as bolts, nuts, and screws so the unit is stable, but leave room for adjustments. Do not fully tighten fasteners until instructed in the assembly steps to do so.

Fill out and mail the warranty card.

Assembly Tips

Read all "Notes" on each page before beginning each step.

While you may be able to assemble the **Y100** using the illustrations only, important safety notes and other tips are included in the text.

Some pieces may have extra holes that you will not use. Use only those holes indicated in the instructions and illustrations.

NOTE: With so many assembled parts, proper alignment and adjustment is critical. While tightening the nuts and bolts, be sure to leave room for adjustments.

CAUTION: Obtain assistance! Do not attempt to assemble the equipment alone as this could result in injury. Review the installation requirements before proceeding with the following steps.

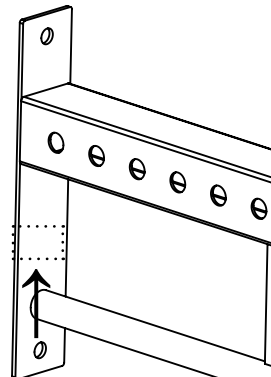

Your S/N# can be found here

RUGGED FITNESS continually seeks ways to improve the performance, specifications and product manuals in order to ensure that only superior products are released from our factories. Please take the time to carefully read through this manual thoroughly. Instructions contained in this document are not intended to cover all details or variations possible with RUGGED FITNESS equipment, or to cover every contingency that may be met in conjunction with installation, operation, maintenance or troubleshooting of the equipment. Even though we have prepared this manual with extreme care, neither the publisher nor the author can accept responsibility for any errors in, or omission from, the information given. Should additional information be required, or should situations arise that are not covered by this manual, the matter should be directed to Service Department at RUGGED FITNESS Inc. in Forest Park, Illinois.

Y100 Hardware Illustration

Part #1

HEX HEAD BOLT M16x80mm

QTY. 8

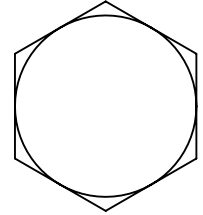
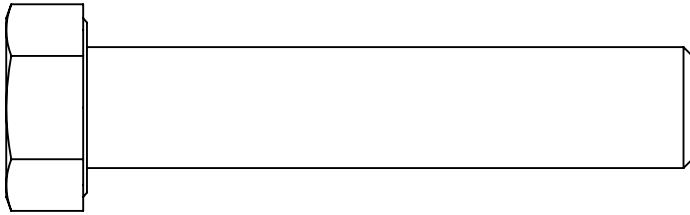

Part #2

HEX HEAD BOLT M16x90mm

QTY. 8

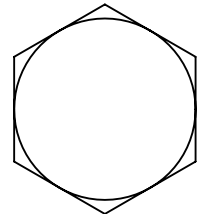
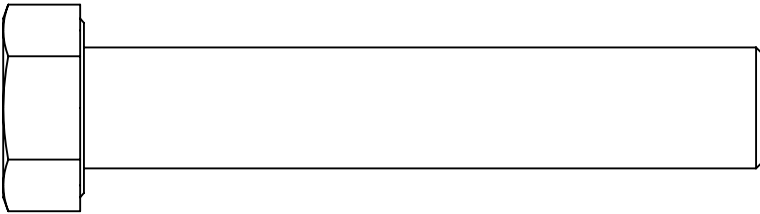

Part #3

HEX HEAD BOLT M16x110mm

QTY. 16

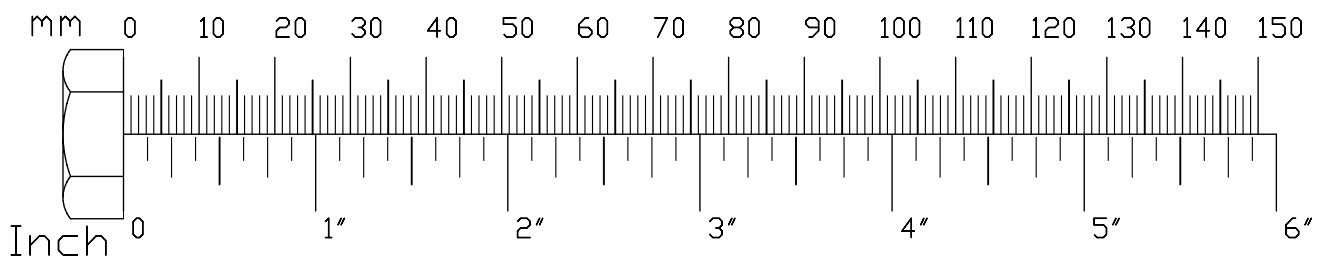
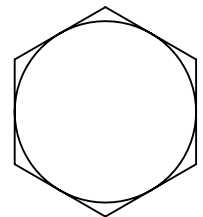
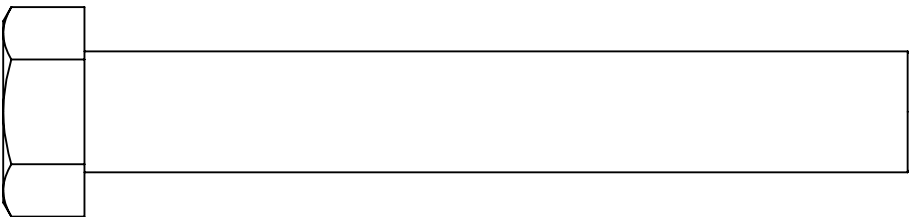

Y100 Hardware Illustration

Part #4

REGULAR FLAT WASHER M16

QTY. 48

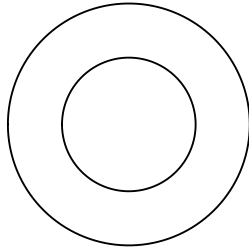

Part #5

LARGE FLAT WASHER M16

QTY. 16

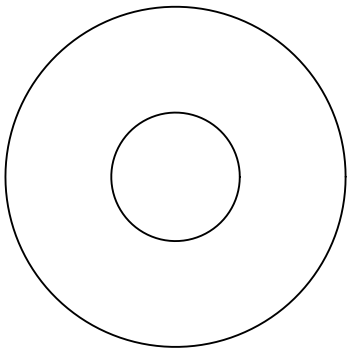

Part #6

NYLON LOCK NUT M16

QTY. 32

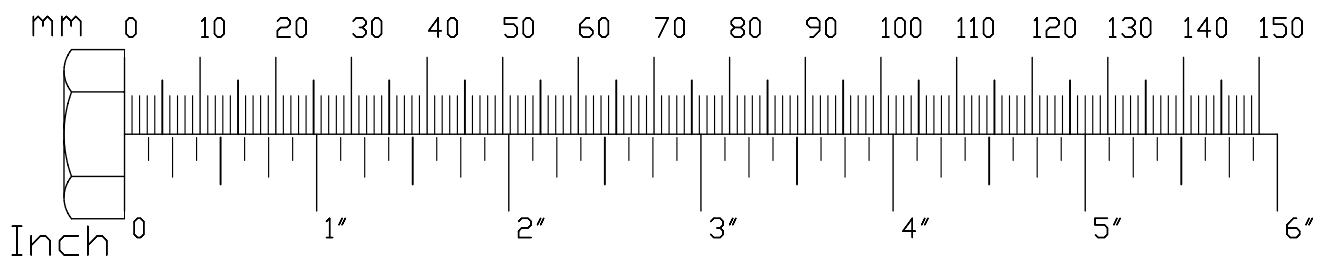
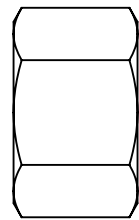
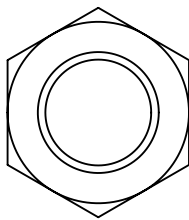

Y100 Parts & Hardware List

Part#	Qty	Description
A	1	RIGHT BASE FRAME
B	1	LEFT BASE FRAME
C	8	STEEL BRACKET
D	4	UPRIGHT
E	1	FRONT CHIN UP BAR
F	1	REAR CROSSBAR
G	2	SIDE CROSSBAR
H	1	DIAMOND PLATE
J	2	50x75mm PLASTIC END CAP
K	1	Left J Cup
L	1	Right J Cup
M	2	Pin
N	2	Pipe
P	2	Quick Release Pin
1	8	M16x80mm HEX HEAD BOLT
2	8	M16x90mm HEX HEAD BOLT
3	16	M16x110mm HEX HEAD BOLT
4	48	M16 REGULAR FLAT WASHER
5	16	M16 LARGE FLAT WASHER
6	32	M16 NYLON LOCK NUT
7	8	M8x16 FLAT HEAD CAP SCREW
8	2	120x40mm PLASTIC INSERT
9	2	47x40mm PLASTIC INSERT
10	8	PROTECTIVE FILM

Parts Illustration

Part A - RIGHT BASE FRAME, QTY 1

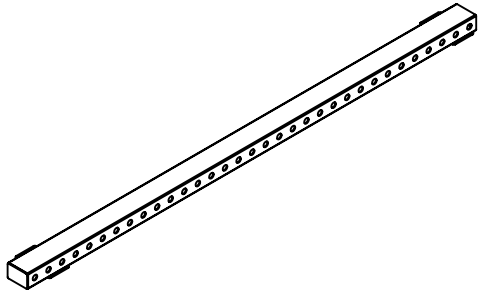

Part B - LEFT BASE FRAME, QTY 1

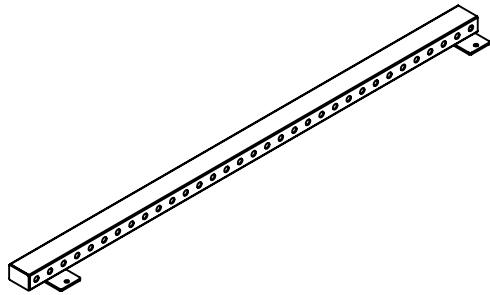

Part C - STEEL BRACKET, QTY 8

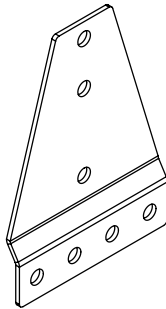

Part D - UPRIGHT, QTY 4

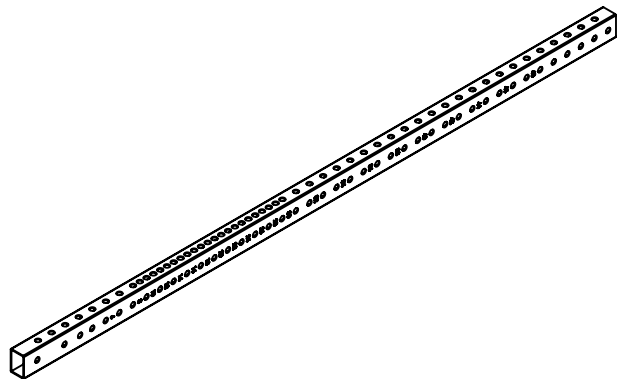

Part E - FRONT CHIN UP BAR, QTY 1

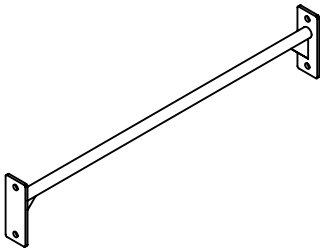

Part F - REAR CROSSBAR, QTY 1

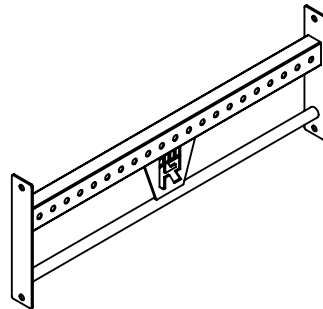

Parts Illustration

Part G - SIDE CROSSBAR, QTY 2

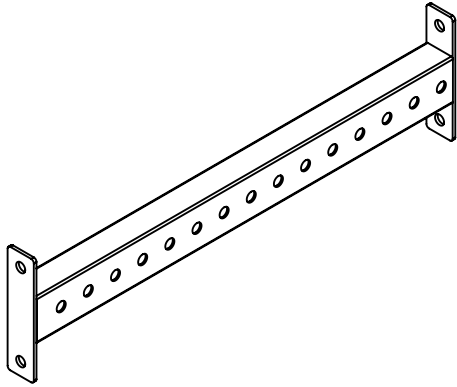

Part H - DIAMOND PLATE, QTY 1

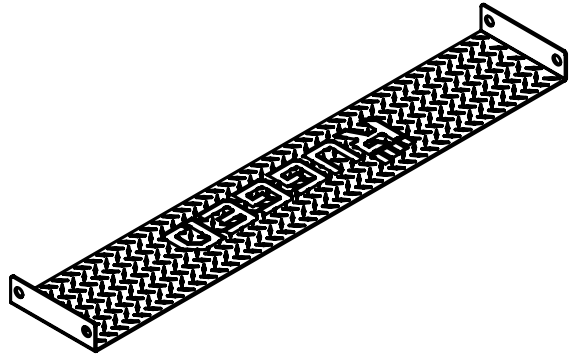

Part J - 50X75mm PLASTIC END CAP, QTY 2

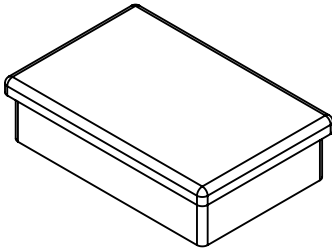

Part K - LEFT J CUP, QTY 1

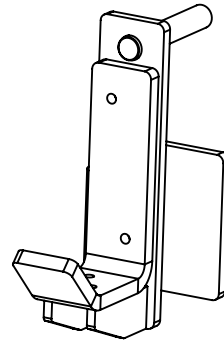

Part L - RIGHT J CUP, QTY 1

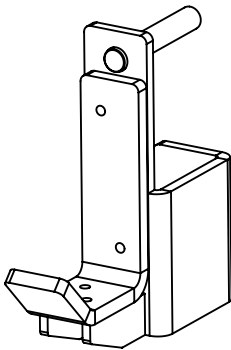

Part M - PIN, QTY 2

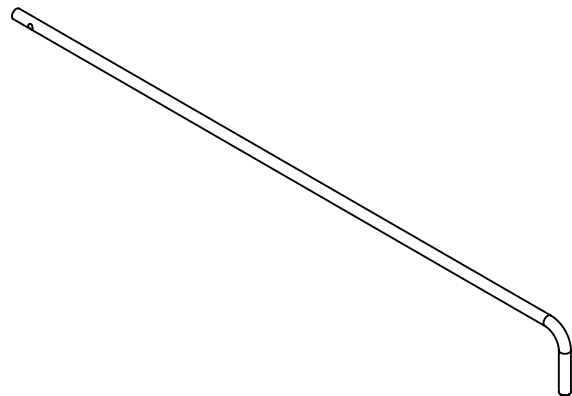

Parts Illustration

Part N - PIPE, QTY 2

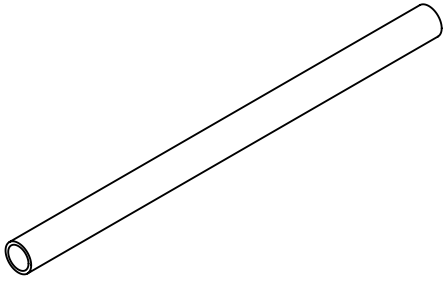

Part P - QUICK RELEASE PIN, QTY 2

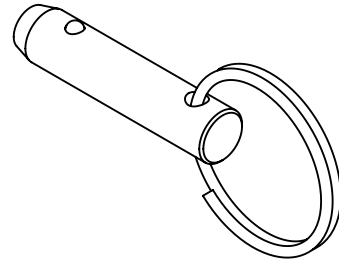

STEP

1

Be careful to assemble all components in the sequence they are presented.

NOTE:

Finger tighten all hardware in this step. DO NOT wrench tighten until instructed. Some components may be pre-assembled. Nylon lock nuts will not fully screw onto bolts, they must be wrench tightened to fully go on.

- 1A.** Attach Base Frames (**A & B**), Diamond Plate (**H**) and Steel Brackets (**C**) together using:
(#3) M16x110mm Hex Head Bolt, QTY 4
(#4) M16 Regular Flat Washer, QTY 8
(#6) M16 Nylon Lock Nut, QTY 4

NOTE 1:

Please refer to the drawing for the correct bolt hole locations. The bolt holes are the 7th and 10th holes from the open end of the Base Frame.

- 1B.** Attach Uprights (**D**) to Steel Brackets (**C**) using:
(#2) M16x90mm Hex Head Bolt, QTY 4
(#4) M16 Regular Flat Washer, QTY 8
(#6) M16 Nylon Lock Nut, QTY 4

- 1C.** Attach Rear Crossbar (**F**) to Uprights (**D**) using:
(#1) M16x80mm Hex Head Bolt, QTY 4
(#4) M16 Regular Flat Washer, QTY 4
(#5) M16 Large Flat Washer, QTY 4
(#6) M16 Nylon Lock Nut, QTY 4

NOTE 2:

It is recommended to install the equipment with at least two persons.

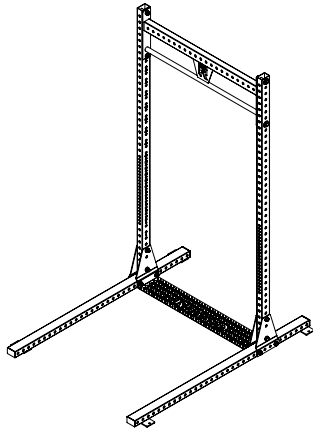

Above shows Step 1 assembled and completed.

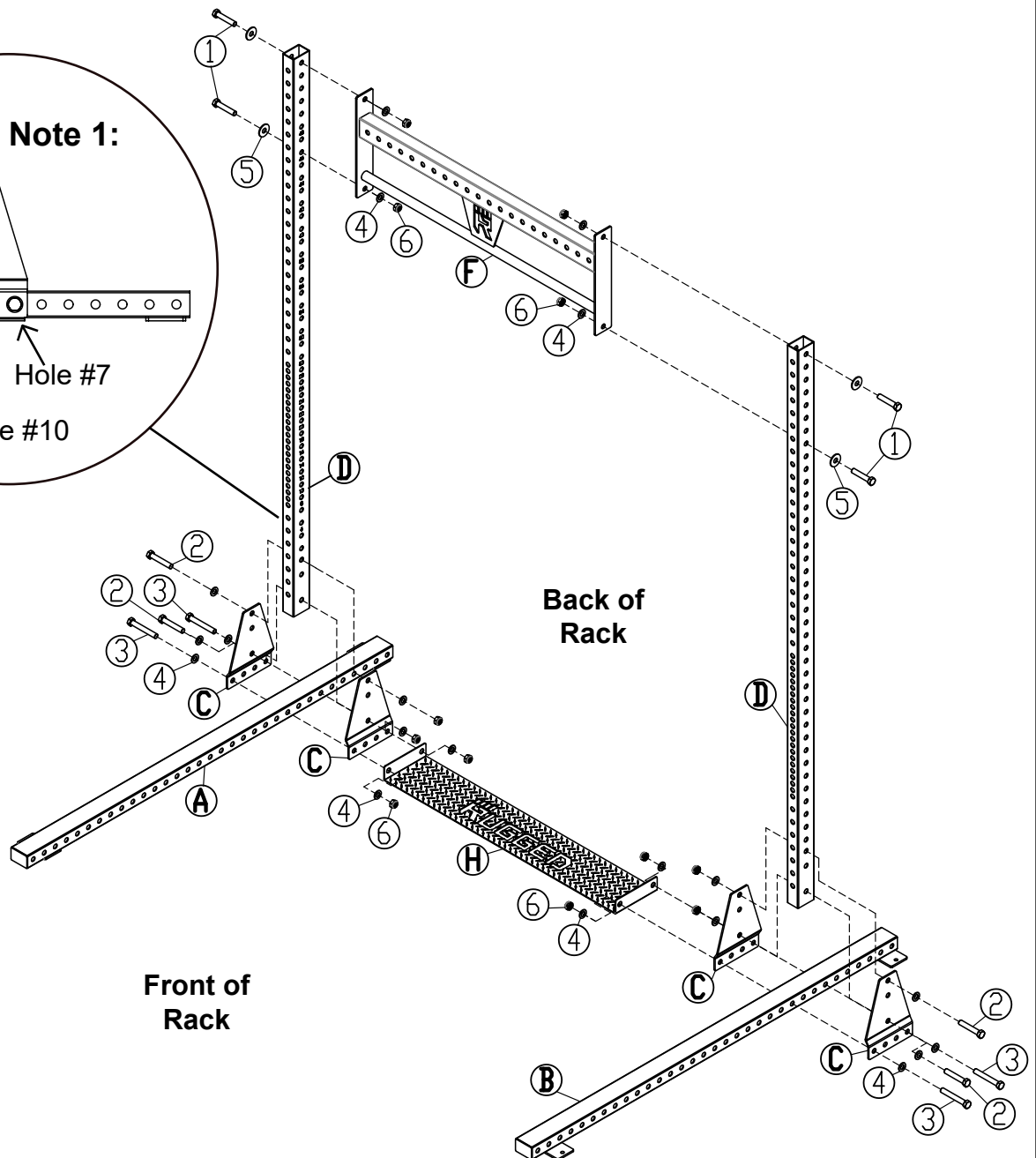
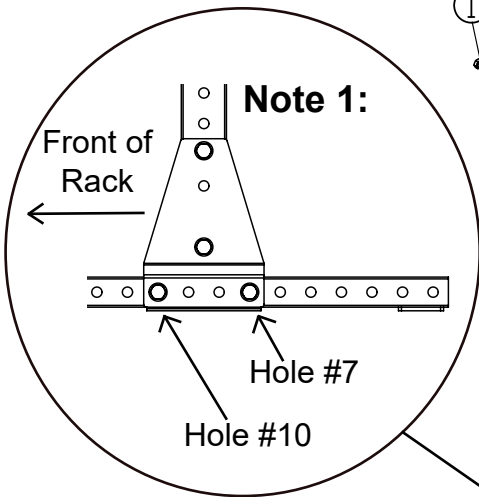

STEP**2**

Be careful to assemble all components in the sequence they are presented.

NOTE:

Finger tighten all hardware in this step. DO NOT wrench tighten until instructed. Some components may be pre-assembled. Nylon lock nuts will not fully screw onto bolts, they must be wrench tightened to fully go on.

- 2A.** Attach Steel Brackets **(C)** to Base Frames **(A & B)** using:
(#3) M16x110mm Hex Head Bolt, QTY 4
(#4) M16 Regular Flat Washer, QTY 8
(#6) M16 Nylon Lock Nut, QTY 4

NOTE:

Please refer to the drawing for the correct bolt hole locations. The bolt holes are the 7th and 10th holes from the front end of the Base Frame.

- 2B.** Attach Uprights **(D)** to Steel Brackets **(C)** using:
(#2) M16x90mm Hex Head Bolt, QTY 4
(#4) M16 Regular Flat Washer, QTY 8
(#6) M16 Nylon Lock Nut, QTY 4

- 2C.** Attach Front Chin Up Bar **(E)** to uprights **(D)** using:
(#1) M16x80mm Hex Head Bolt, QTY 4
(#4) M16 Regular Flat Washer, QTY 4
(#5) M16 Large Flat Washer, QTY 4
(#6) M16 Nylon Lock Nut, QTY 4

NOTE 2:

It is recommended to install the equipment with at least two persons.

STEP
2

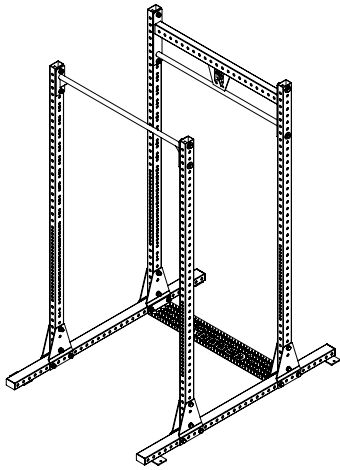

Above shows Step 2 assembled and completed.

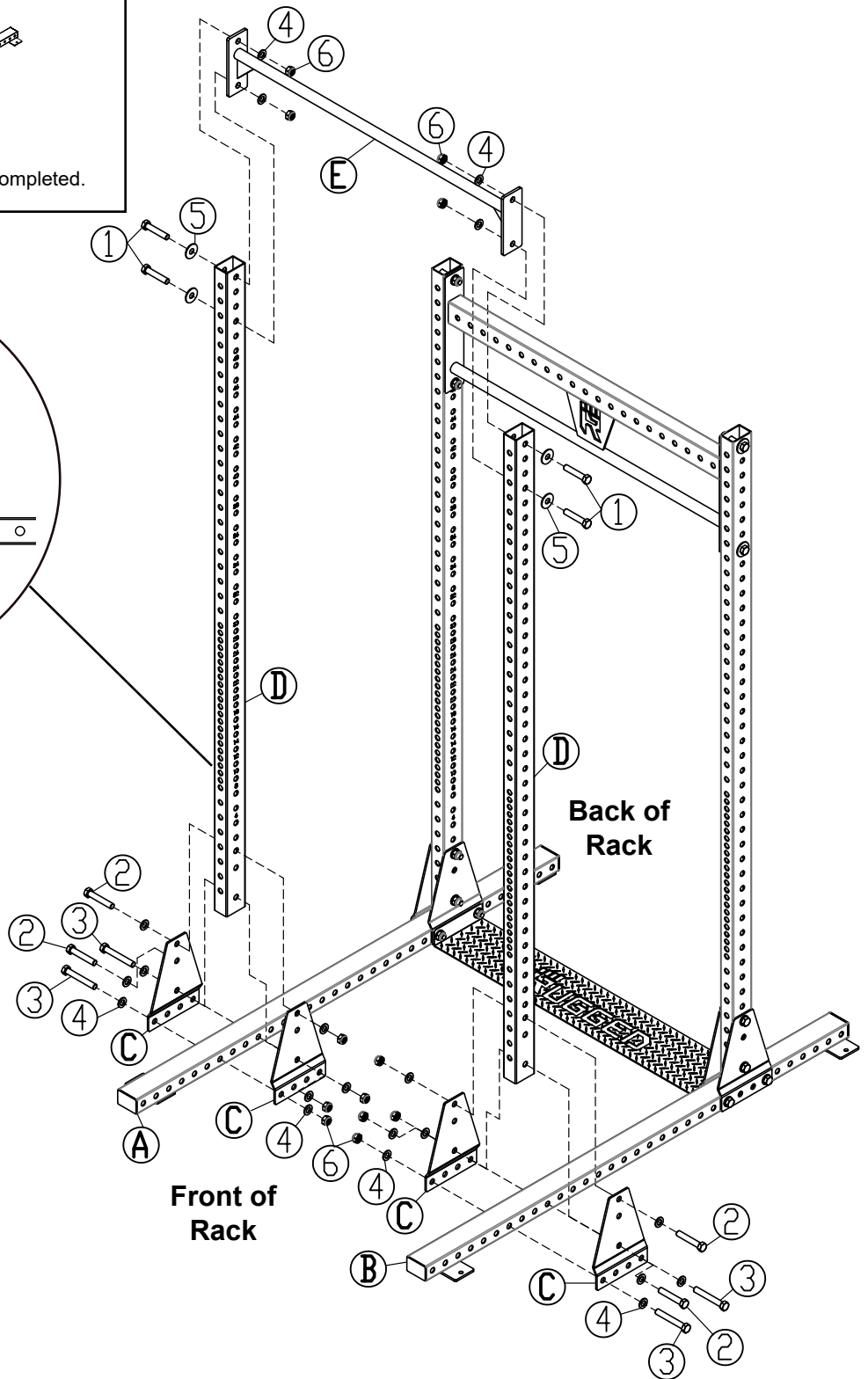
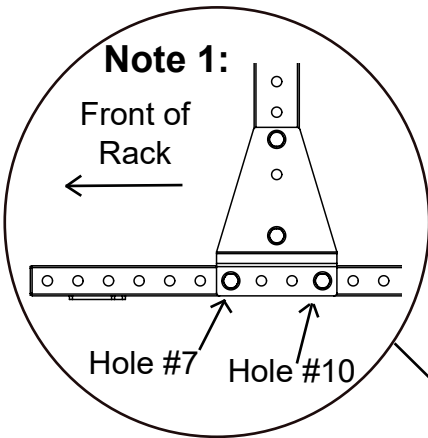

STEP**3**

Be careful to assemble all components in the sequence they are presented.

NOTE:

Finger tighten all hardware first in this step. Wrench tighten ALL hardware at the end of STEP 3A. Some components may be pre-assembled. Nylon lock nuts will not fully screw onto bolts, they must be wrench tightened to fully go on.

3A. Attach Side Top Frames (**G**) to uprights (**D**) using:

8 - (#3) M16x110mm Hex Head Bolt, QTY 8

8 - (#4) M16 Regular Flat Washer, QTY 8

8 - (#5) M16 Large Flat Washer, QTY 8

8 - (#6) M16 Nylon Lock Nut, QTY 8

3B. Insert Plastic End Caps (**J**) onto the open ends of the Base Frames (**A & B**).

NOTE 1:

SECURELY anchor the machine to the floor using the anchor holes provided. Please consult a professional contractor for the actual anchoring of the machine.

NOTE 2:

It is recommended to install the equipment with at least two persons.

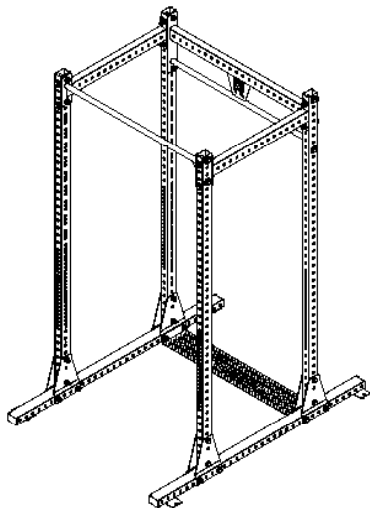

Above shows Step 3 assembled and completed.

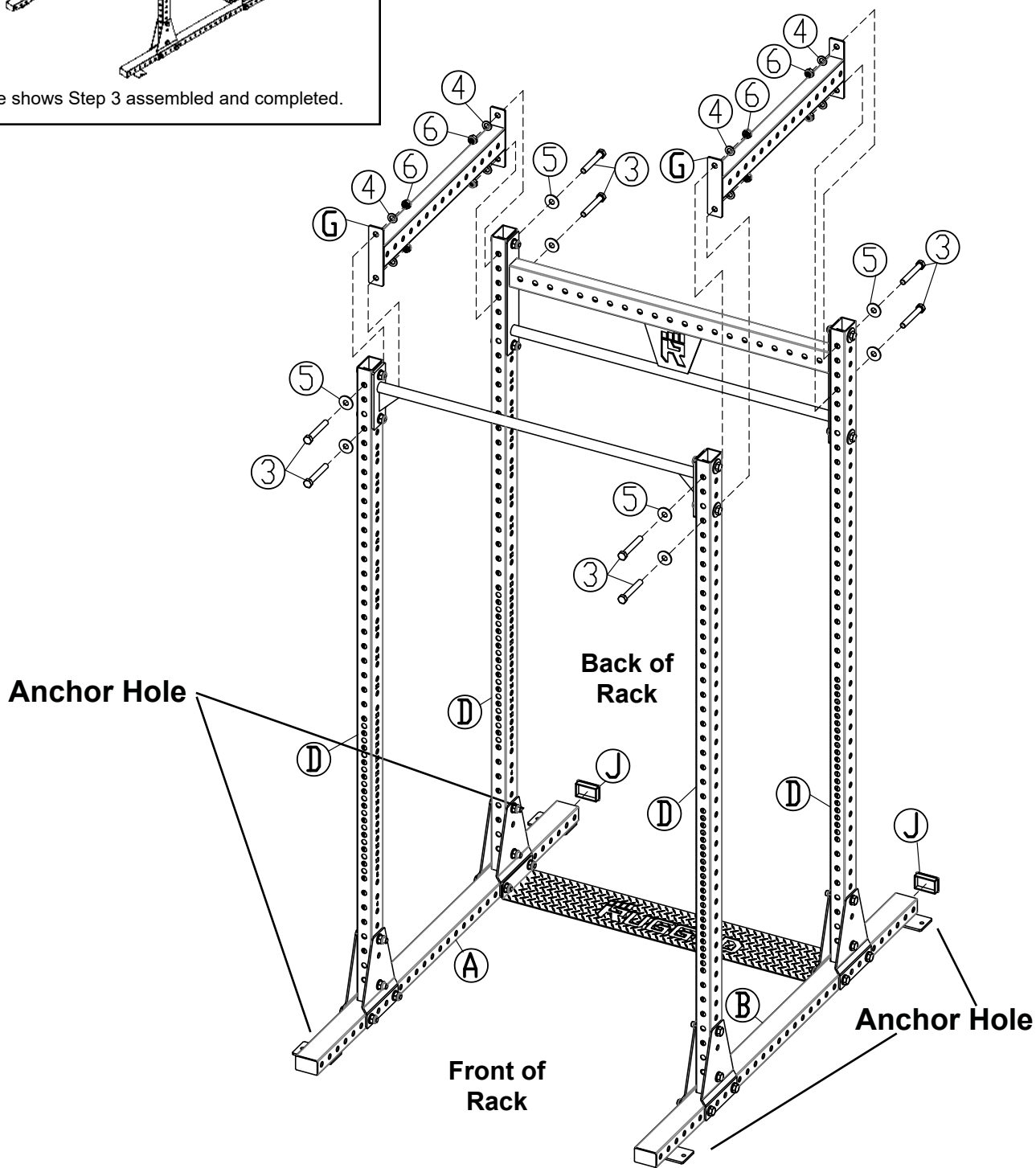

STEP**4**

Be careful to assemble all components in the sequence they are presented.

NOTE:

Some components may be pre-assembled. Nylon lock nuts will not fully screw onto bolts, they must be wrench tightened to fully go on.

Adjustable J Cups and Pipe & Pin Safeties

- 4A.** Attach Left & Right J Cups (**K & L**) to uprights (**D**).
- 4B.** Hold Pipes (**N**) between the Uprights of the Rack (**D**) and Insert the Chrome Pins (**M**) into the Pipes (**N**) and Uprights (**D**).
- 4C.** Insert the Quick Release Pins (**P**) into the end of the Chrome Pins (**M**).

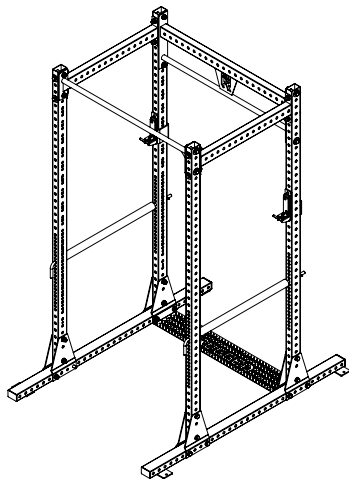

Above shows Step 3 assembled and completed.

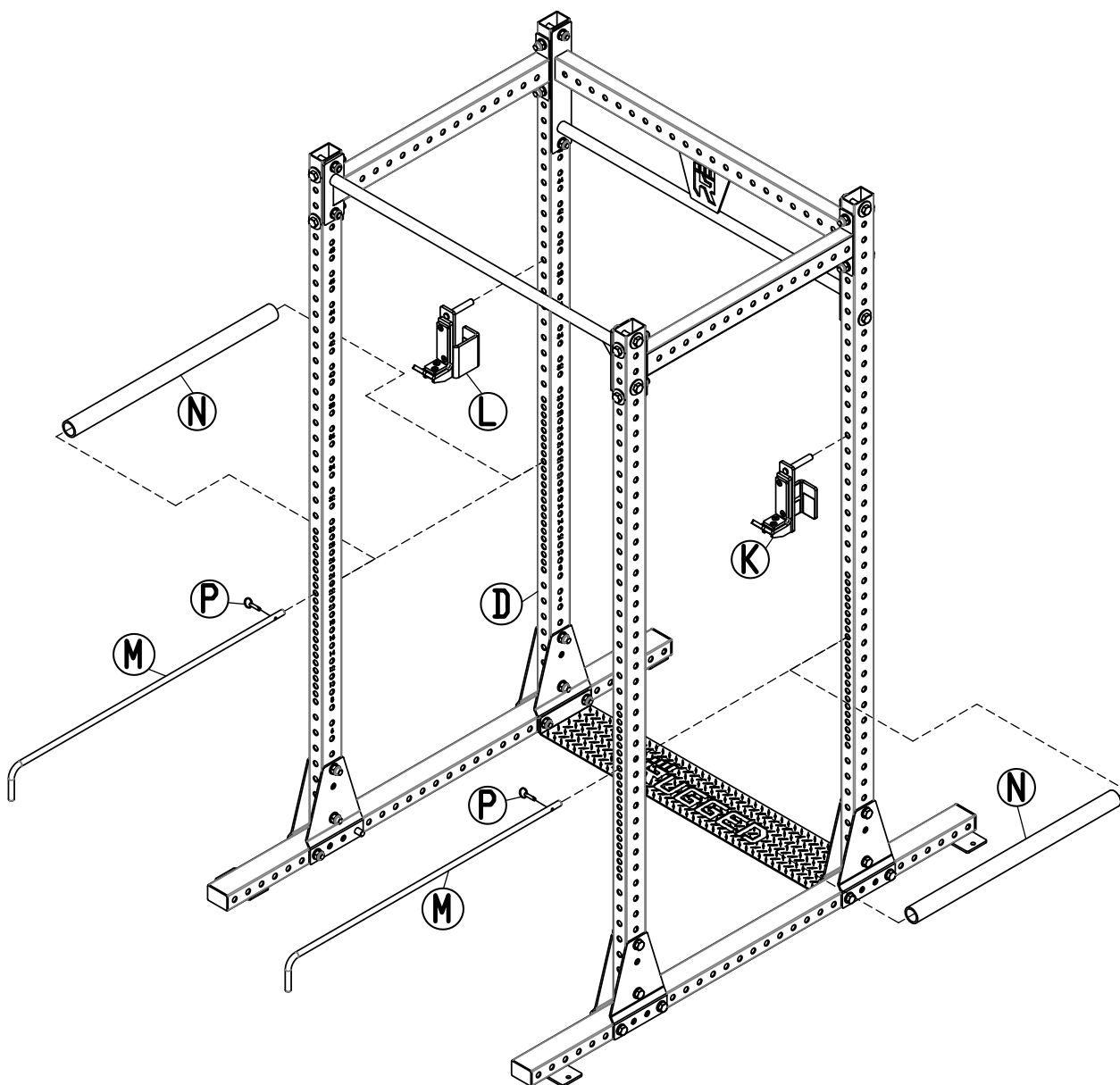

Notes

Y100 Exploded View

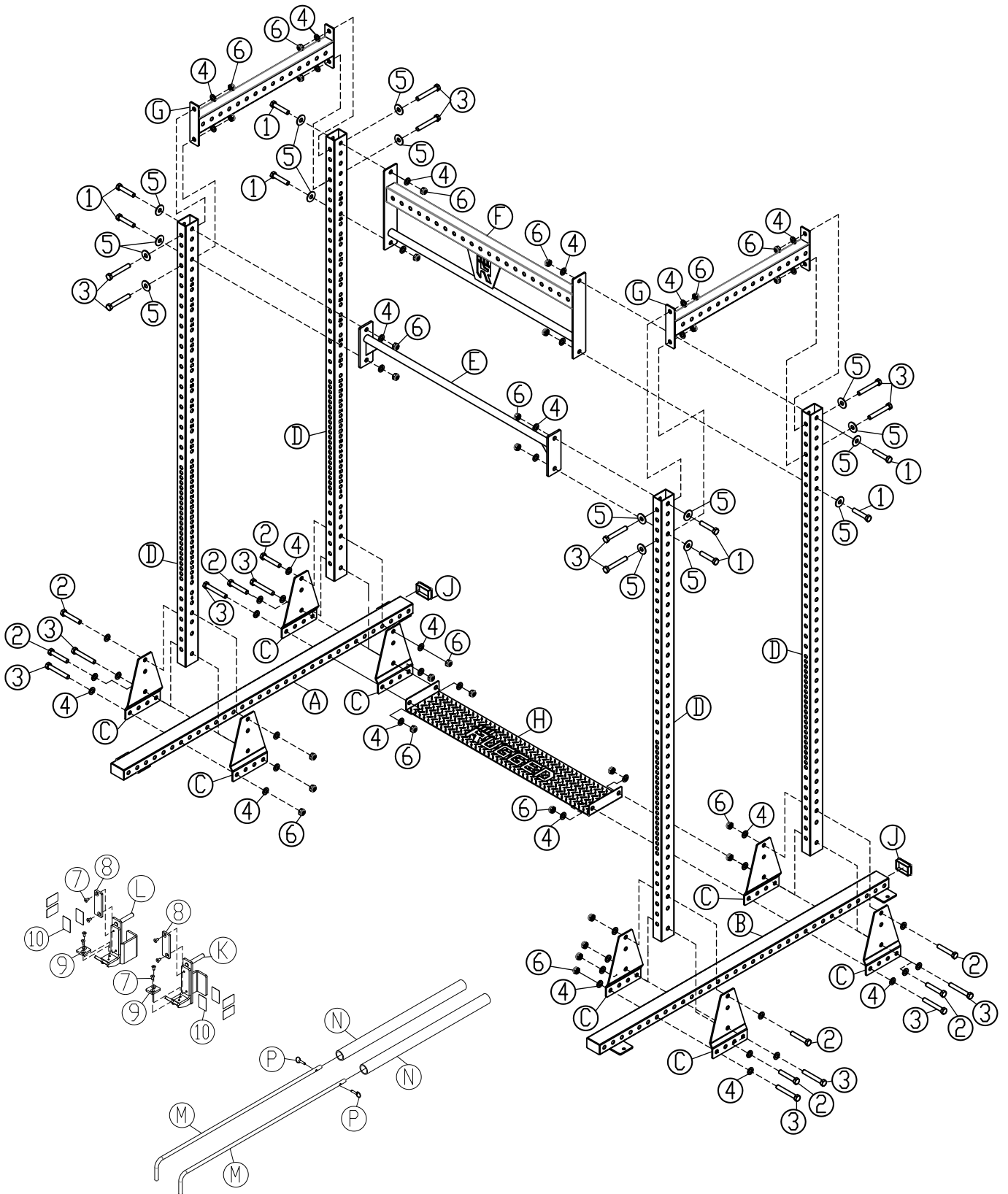



Y100

PLEASE WRITE YOUR SERIAL NUMBER IN THE BOXES BELOW

S/N # 013469----

1900 S. Des Plaines Ave.
Forest Park, IL 60130
Phone:(708)427-3555
Fax:(708)427-3556
Hours: M-F 8:30 - 5:00 CST
www.ruggedfitness.com